



**Advanced Configuration**

**Ecological and economical**

- ▶ ISUZU engine with low fuel consumption, low noise and low emission can provide strong power
- ▶ Negative flow control system maximizes work efficiency.
- ▶ Smart electronic control system can achieve the balance of power and hydraulic load

**Multiple applications**

- ▶ Different boom and bucket combinations maximize utilization of different conditions
- ▶ Multi-functional machine system meets various job requirements such as digging and crushing

**Comfortable operational experience**

- ▶ Air Conditioner and Heater and multi-channel stereo air input system ensure the appropriate temperature
- ▶ Equipped with advanced audio system
- ▶ The cab equipped with hydraulic shock absorbers has multi-directional and multi-level adjustment functions



**Excellent after-sales service**

- ▶ Global after-sales service system and quick response mechanism
- ▶ Real-time technical consultation and maintenance

**Convenient maintenance**

- ▶ Easy maintenance design concept makes your maintenance done without dead angle
- ▶ Daily maintenance points are within your reach
- ▶ The embedded sealing strip is featured with good dustproof and waterproof effects

**Safe and durable**

- ▶ Upgraded undercarriage structure improves load bearing performance
- ▶ Strengthened key stress-bearing parts of chain links
- ▶ Strengthened and wear-resistant bucket is more durable

**Ecological And Economical**

▶ The imported ISUZU engine with original packaging has strong power, and meets the requirements of high efficiency operation. With low fuel consumption, low noise and low emission, it adopts mechanical oil supply mode and acts good adaptability of oil products.

▶ By adopting the internationally advanced and mature and reliable negative flow control system, and increasing the flow distribution to each action cylinder provided by the multi-way valve through the dual pump confluence, so as to provide powerful digging capabilities for the machine and maximize work efficiency.

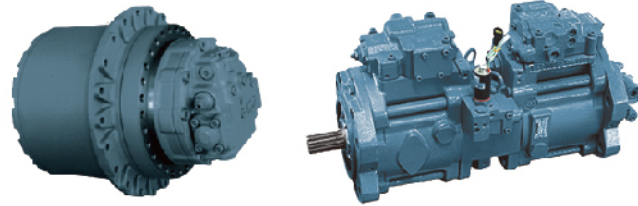
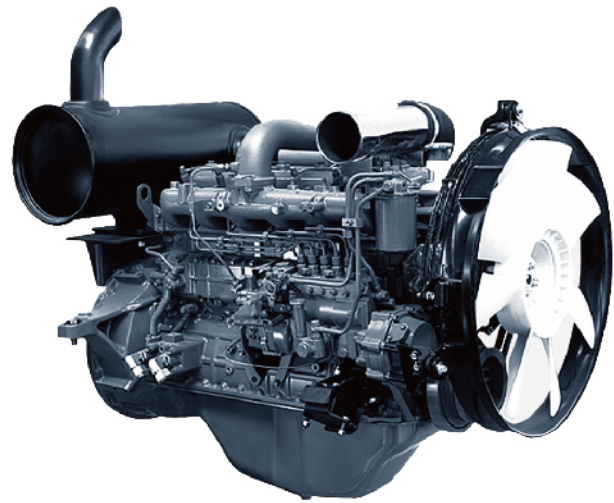

▶ A new generation of intelligent electronic control system, which integrates intelligence, environmental protection and safety, to achieve the balance of power and hydraulic load; Intelligent electronic control can achieve remote control, with new memory function, the operation process will be recorded at any time, and power conversion device will optimize power use.

**Comfortable And Safe**

▶ The new luxury and comfortable driving system is designed with ergonomics. Equipped with hydraulic shock absorbers, it has multi-directional and multi-level adjustment functions, and unique lumbar support function to make driving more comfortable and effectively reduce driver fatigue.



▶ Equipped with high-power air conditioner, a multi-channel stereo air input system, and advanced audio system, many operations are comfortable to perform and within your reach.

▶ The new silicon oil shock absorber adopts multi-point distribution, effectively reduces the vibration in the cab, and makes the driving environment more comfortable and safe



## Reliable And Durable

- ▶ Adopt a large number of special technologies and imported high-strength, wear-resistant steel to develop and manufacture structural parts; It will greatly enhance strength of products and prolong their service life, so as to cope with adverse working conditions easily.



- ▶ Chain links that take on stress are strengthened so that its strength and impact resistance are improved to extend the crawler's service life.
- ▶ Standard lengthened and widened heavy-duty chassis and optimized box structure, will allow for high strength, low center of gravity and better working stability; With integrated heavy-duty rail clamps, better protection and longer service life will be achieved.

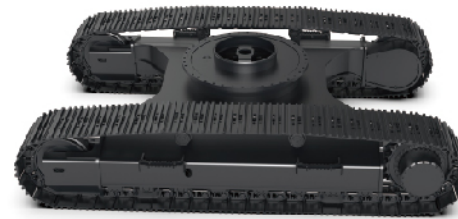

- ▶ Strong and durable working equipment: heavy-duty reinforced boom and arm can ensure powerful digging force under severe working conditions.



- ▶ The newly designed high-strength and high wear-resistant bucket; Optimize structural distribution on effective parts, thicken and increase the reinforcement plate; Side teeth, bucket teeth, lip protection and other detailed parts specially designed for mining operations will greatly improve the bucket strength, wear resistance and overall service life.



## Maintenance And Service

- ▶ Daily maintenance points are within your reach: Whether it is fuel filter, oil filter, pilot filter, you can directly service it on the ground, the operation is easy and cost saving.



- ▶ The embedded sealing strip is used to prevent dust, sand and water from entering the lubricating oil bath, which has good dustproof and waterproof effects, strong versatility, and convenient maintenance and observation .
- ▶ The working condition parameters of the whole machine are displayed on the color LCD screen, which is reliable and elegant. With machine maintenance reminder, users can operate at ease.
- ▶ A wide range of after-sales service system, quick-response rescue mechanism can ensure that you use at ease.



### Multiple Application Conditions

The independently developed multi-functional intelligent work tool control system can realize crushing, shearing, cleaning, compacting, milling, transporting, pinching, grasping, scraping, loosening, lifting, and other operations, and can truly integrate multiple operations into one machine.

Different boom and bucket combinations can adapt to various working conditions.



**Standard Equipment**

	Name of equipment	XE335C
Engine	Engine model	AA-6HK1XQP
	Automatic preheating	
	Oil-water separator with water level indication sensor	
	Radial seal air cleaner	
	Cooling components of 50°C high temperature environment	
	Air prefilter	
	Radiator dust screen	
	Fuel marker	
	Air pressure difference indicator	
	Automatic idle speed	
Hydraulic system	Boom/arm flow regeneration	
	Auxiliary hydraulic valve	
	Reverse rotation damping valve	
	Automatic rotation parking brake	
	Hydraulic buffer valve	
	Straight hydraulic circuit	
	Boom priority valve	
	Rotary logic valve	
	Hydraulic oil ISO VG 46	
	Rotary anti-sway valve	
Cab and interior trim	Gauge pressure monitoring	
	Pressurized cab	
	Fully adjustable mechanical suspension seat	
	Adjustable seat armrest	
	Seat belt (51 mm [2 "] wide)	
	Openable windscreen with auxiliary device	

Cab and interior trim	Double laminated windshield and other toughened windows
	Sliding door upper window
	Bi-directional air outlet air conditioner with defroster (automatic type) (pressurization function)
	Color liquid crystal display capable of displaying warning information, filter / liquid replacement information and working hours
	Control handle
	Travel control pedal with detachable manual control lever
	Two stereo speakers
	Beverage cup holder
	Coat and hat hook
	Cleanable floor mat
Safety and security configuration	Air conditioning system
	High and low gears shift
	One-key boost mode
	Top sunroof
	Intermittent multi-gear wiper
	Cup holder/envelope
	Heating and cooling storage box
	Radio receiver
	Driving door locks and cabin locks
	Alarm horn
Safety and security configuration	Isolation plate between engine and oil pump chamber
	Emergency stop switch of engine
	Rear window emergency exit
	Battery circuit breaker
	Boom and arm retaining valve
	Overheat alarm
	Safety handrails and pedals
	Anti-skid plate/anti-skid paste

Safety and security configuration	Hydraulic safety locking lever
	Emergency escape hammer
Chassis system and shield	Left and right rearview mirrors
	Bottom frame traction ring
	600 mm (24 ") three-rib track shoe
Working device	Protective device kit: chassis bottom sealing plate, walking motor sealing plate
	Boom 6.4m
	Arm 2.67m
Lamp	Bucket 1.4m <sup>3</sup> strengthened bucket
	Boom working lamp at left and right side
	Working lamp installed on the right side of storage box
	Lamp inside the cab
Electrical system	Front working lamp installed on the top of cab
	Battery (2×850CCA)
	50A Alternator
	5KW start motor
Counterweight	24V Cigar lighter
	6.9t Counterweight
Technology	XEICS intelligent system

Engine	Fast fill fuel system
Hydraulic system	Hydraulic pipeline: quartering hammer and thumb pliers
	Operating modes switch
	Hydraulic oil ISO VG 32, 68
Cab and interior trim	Spare valve disc
	Heated air suspension seat with cushion
	Retractable seat belt (51 mm [ 2 " ] wide)
	Onboard oxygen device
	Fire extinguisher
Chassis system and shield	Reserved switch for auxiliary equipment
	Shade curtain
	600 mm (24 ") double-rib track plate
	700 mm (28 ") double-rib track plate
	800 mm (31 ") double-rib track plate
	700mm (28 ") three-rib track plate
	800 mm (31 ") three-rib track plate
	Extended chassis
	Track rubber block
	Full-length track guard ( two-piece, lower frame needs to be replaced )
Working device	Arm 2.9m
	Arm 3.2m
	1.4-1.5m <sup>3</sup> Rock bucket
	1.4-1.8m <sup>3</sup> Strengthened bucket
	1.4-1.8m <sup>3</sup> Earthwork bucket
	Quick coupler
	Hydraulic breaker
Hydraulic thumb pliers	
	Ripper

## Optional Equipment

Name of equipment	XE335C
Oil-water separator with heater (24V)	
Oil bath type air prefilter	
Oil and water quick discharge device	
arm concentration	
Fuel refueling pump 50L/min	

**Working device**

Vibratory plate compactor
Hydraulic shear
Grip
High frequency braker
Clam shell bucket
Plum-blossom shape grab bucket
Sreen-type bucket
Pipe grab machine
Travel alarm
Explosion-proof valve of boom and arm pipeline
Rotating alarm light
Counterweight reaview mirror
Falling object protective structure (FOPS)
Roll off protection structure(ROPS)
12V Cigar lighter
Camera
5V USB interface
12V Power interface
Front working lamp installed on the top of cab
Rear working lamp installed on the top of cab
200kg vice counterweight(two for options)
Electric self-lubrication system
Arm concentration lubrication

**Main Specifications**

Item	Unit	Parameters	
Model	/	XE335C	
Operating weight	Kg	33800	
Bucket capacity	m <sup>3</sup>	1.4-1.6	
Engine	Model	/ ISUZU AA-6HK1XQP	
	Direct injection	/	√
	Four strokes	/	√
	Water cooling	/	√
	Turbo-charging	/	√
	Air to air intercooler	/	√
	No. of cylinders	/	6
	Rated power/speed	kw/rpm	190.5/2000
	Maximum torque/speed	N.m	872.8/1700
	Displacement	L	7.79
Main Performance	Travel speed (H/L)	km/h	5.5/3.3
	Swing speed	r/min	9.7
	Gradeability	°	≤35
	Ground pressure	kPa	66
	Bucket digging force	kN	263
	Arm digging force	kN	225
	Maximum tractive force	kN	261
	Main pump	/	Two piston pumps
	Rated flow of main pump	L/min	2×280
	Main safety valve pressure	MPa	34.3/37
Hydraulic System	Travel system pressure	MPa	34.3
	Swing system pressure	MPa	26.5
	Pilot system pressure	MPa	3.9



Item	unit	Main specifications
Oil Capacity	Fuel tank capacity	L 630
	Hydraulic tank capacity	L 320
	Engine oil capacity	L 28
Standard	Length of boom	mm 6400
	Length of arm	mm 2670
	Bucket capacity	m <sup>3</sup> 1.4
Optional	Length of boom	mm /
	Length of arm	mm 3200
	Bucket capacity	m <sup>3</sup> 1.6

## Dimensions

Item	Unit	Parameters
A Overall length	mm	11388
B Overall width	mm	3190
C Overall height	mm	3515
D Width of platform	mm	2950
E Track length	mm	4725
F Overall width of chassis	mm	3190
G Track shoe width	mm	600
H Wheel base of crawler	mm	3813
I Track gauge	mm	2590
J Counterweight clearance	mm	1170
K Min. ground clearance	mm	495
L Min. tail swing radius	mm	3570
M Height of track	mm	940

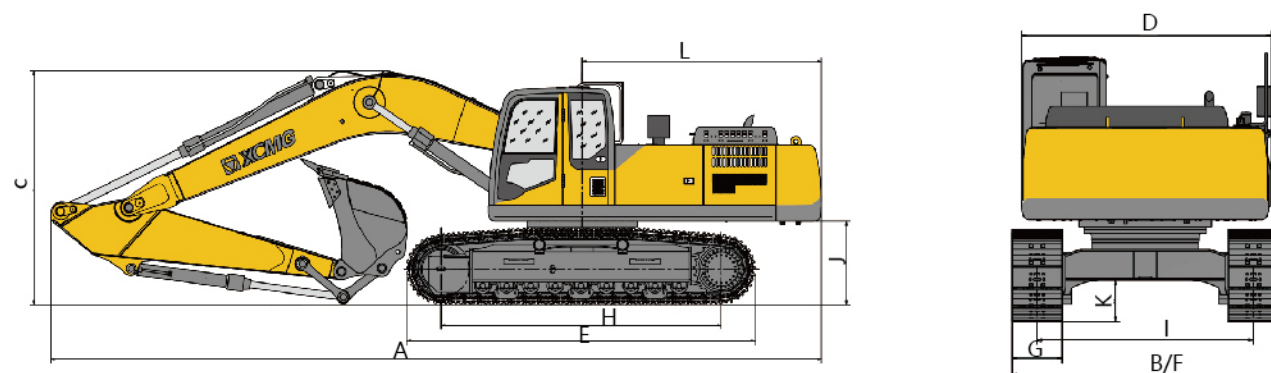

## Working Range

Item	Unit	Parameters
A Max. digging height	mm	10074
B Max. dumping height	mm	6898
C Max. digging depth	mm	6972
D Maximum depth cut for 2240mm(8 ft) level bottom	mm	6728
E Max. vertical wall digging depth	mm	5366
F Max. digging radius	mm	10650
G Min. swing radius	mm	4424

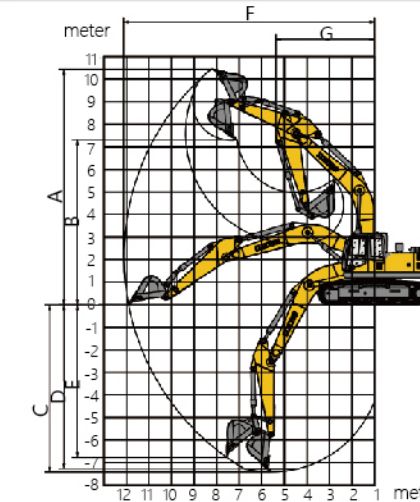

## Lifting Capacity

Lifting point height (m)	Rated lift capacity – Straight ahead (back) (kg)					Rated lift capacity – over-side (kg)				
	Lifting point radius (m)				Lifting capacity at maximum radius	Lifting point radius (m)				Lifting capacity at maximum radius
	3	4.5	6	7.5		3	4.5	6	7.5	
8.7					*10323					9427
7.5					*9994					7142
6			*10525	9885	8898			9138	6431	5719
4.5		*15135	*11951	9658	7821		13199	8662	6226	4988
3		*18957	13101	9364	7293		11993	8128	5691	4612
1.5			12609	9100	7140			7700	5723	4480
Ground										
-1.5	*14610	19678	12265	8893	7984	*14610	11122	7401	5537	4954
-3	*24921	*18894	12388		9445	22303	11306	7508		5824
-4.5	*19654	*15179			*11330	*19654	11708			7974

Capacities marked with an asterisk(\*) are limited by hydraulic capacities.



Machmall.com is an electromechanical product platform officially launched by XCMG, aiming to provide global customers with a complete set of high-quality construction machinery solutions and supporting equipment.

Xuzhou Construction Machinery Group Co., Ltd. (XCMG Group), founded in 1943, is the fourth largest worldwide construction machinery manufacturer and the largest in China with products covering 183 countries and regions.

XCMG have 12 complete solutions: Crane lifting, Mining Construction, Earth-moving Solutions, Road Machinery, Concrete Equipment, Tunnel and Underground Space Construction, Mobile Elevating Work Platform (MEWP), Piling and Non-excavation Equipment, Transportation Equipment, Environmental Sanitation Equipment, Firefighting, Safety and Emergency Rescue

徐工徐工，助您成功

— XCMG for your success —



 <https://www.machmall.com/>

 [machmall@xcmg.com](mailto:machmall@xcmg.com)

 0086 18652 183963  
86-516 8773 9797

